

Cartridge Safety Relief Valve

Product Bulletin 72-10 A

Type: CSR, CSRH



Purpose:

Parker's cartridge safety relief valves (CSRV) are designed to offer the highest level of protection while maintaining easy serviceability. The CSRV was designed from the existing Parker SR and SRH safety relief valve housing, which allows for a simple and easy upgrade path to the new cartridge based design.

As local or state codes govern the frequency of valve replacement, the CSRV is a cost effective alternative to standard safety relief valve designs.

Typical applications for the CSRV include compressor packages, accumulator vessels and anywhere else protection from overpressure is required.

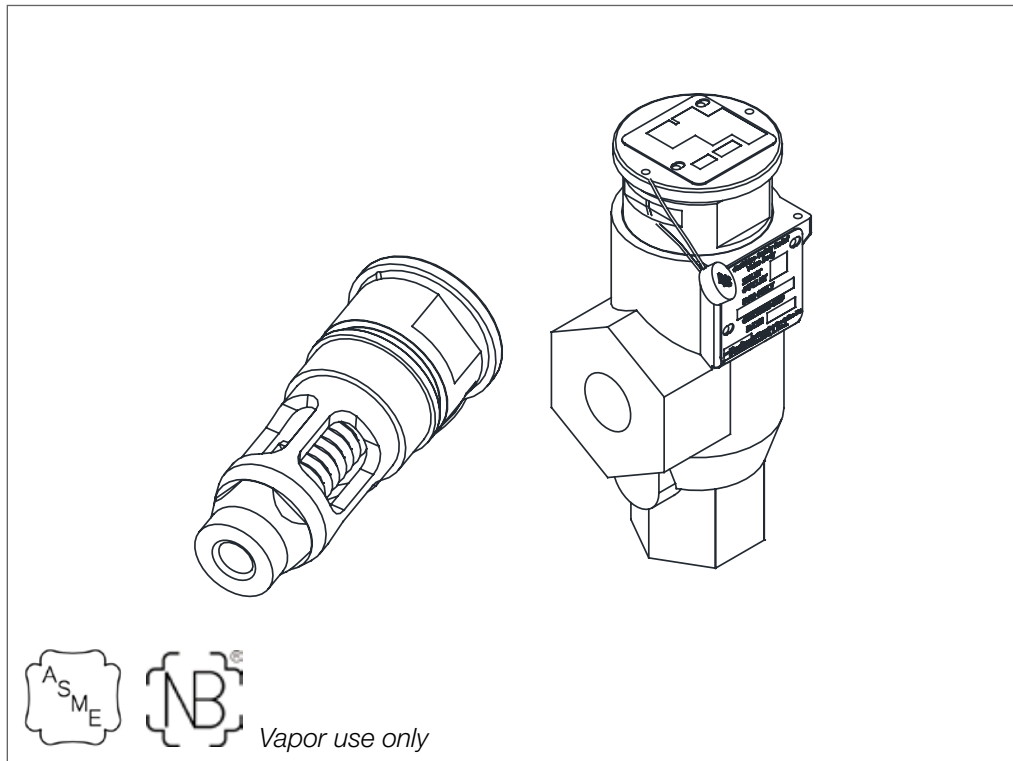

Contact Information: Product Features:

Parker Hannifin Corporation
Refrigerating Specialties Division
2445 South 25th Avenue
Broadview, IL 60155-3891

phone (708) 681-6300
fax (708) 681-6306

www.parker.com/refspec

- Suitable for ammonia and halocarbon refrigerants
- ASME Boiler and Pressure Vessel Code, Section VIII, Division 1 compliant
- ANSI/ASHRAE 15 safety standard for refrigeration systems
- Stainless steel cartridge and internal components
- Same lay in length as SR and SRH series safety relief valves
- Cartridge based design allows for replacement while housing remains in the system
- Non-stick PTFE seat
- Set pressure tolerance of $\pm 3\%$
- Unaffected by vibration



ENGINEERING YOUR SUCCESS.

Table of Contents

Technical Data 2 Dimensional Information 5
 Function and Design 3 Nameplate Information 6
 Selection Data 4 Maintenance and Service 6
 Installation 4 Parts Kit Reference 7

Technical Data

Temperature Range -40°C to 150°C (-40°F to 300°F) Pressure Setting Range 10.3 to 27.6 barg (150 to 400 psig)
 Maximum Rated Pressure 27.6 bar (400 psig) ±3% set pressure tolerance

Valve Type	Connection (FPT)		Orifice Diameter	Flow Coefficient		Pressure Setting (psig)	Flow Capacity		Manifold			
	Inlet	Outlet		Kv	Cv		Lbs. Per Min Air	SCFM Air	Connection (FPT)		Flow Coefficient	
									Inlet	Outlet	Kv	Cv
CSR1	1/2"	3/4"	1/2"	1.07	1.25	150	10	130	M1 Manifold Provides 1/2"	1/2"	Port 1 6.2	Port 1 7.2
						200	13	170				
						250	16	210				
						300	19	250				
						350	22	290				
						400	25	329				
CSR2	1/2"	1"	1/2"	2.02	2.36	150	19	246	M1 Manifold Provides 1/2"	1/2"	Port 1 6.2	Port 1 7.2
						200	25	321				
						250	30	397				
						300	36	472				
						350	42	547				
						400	48	622				
CSR3	3/4"	1 1/4"	3/4"	3.12	3.61	150	29	377	M1 Manifold Provides 3/4"	3/4"	Port 1 10.5	Port 1 12.2
						200	38	493				
						250	46	608				
						300	55	724				
						350	64	839				
						400	73	955				
CSR4	3/4"	1 1/2"	3/4"	4.07	4.70	150	37	491	M1 Manifold Provides 3/4"	3/4"	Port 1 10.5	Port 1 12.2
						200	49	641				
						250	60	791				
						300	72	945				
						350	83	1091				
						400	94	1241				

Table 1: CSR Technical Data

Valve Type	Connection (FPT)		Orifice Diameter	Flow Coefficient		Pressure Setting (psig)	Flow Capacity		Manifold			
	Inlet	Outlet		Kv	Cv		Lbs. Per Min Air	SCFM Air	Connection (FPT)		Flow Coefficient	
									Inlet	Outlet	Kv	Cv
CSRH1	1/2"	3/4"	1/2"	3.80	4.44	150	35	463	M1 Manifold Provides 1/2"	1/2"	Port 1	Port 1
						200	46	605			6.2	7.2
						250	57	747			Port 2	Port 2
						300	68	889			7.1	8.2
						350	79	1031				
						400	89	1173				
CSRH2	1/2"	1"	1/2"	3.80	4.44	150	35	463	M1 Manifold Provides 1/2"	1/2"	Port 1	Port 1
						200	46	605			6.2	7.2
						250	57	747			Port 2	Port 2
						300	68	889			7.1	8.2
						350	79	1031				
						400	89	1173				
CSRH3	3/4"	1"	1/2"	3.80	4.44	150	35	463	M1 Manifold Provides 3/4"	3/4"	Port 1	Port 1
						200	46	605			10.5	12.2
						250	57	747			Port 2	Port 2
						300	68	889			11.0	12.7
						350	79	1031				
						400	89	1173				
CSRH4	1"	1 1/4"	3/4"	6.62	7.65	150	61	798	M1 Manifold Provides 1"	1"	Port 1	Port 1
						200	79	1042			19.3	22.3
						250	100	1287			Port 2	Port 2
						300	117	1530			18.8	21.7
						350	135	1775				
CSRH5	1 1/4"	1 1/2"	3/4"	7.98	9.23	150	73	963	M1 Manifold Provides 1 1/4"	1 1/4"	Port 1	Port 1
						200	96	1258			24.3	28.1
						250	118	1553			Port 2	Port 2
						300	141	1848			22.5	26.0
						350	163	2142				

Table 2: CSRH Technical Data

Function and Design

Safety relief valves are used to protect against or limit pressure build up in refrigeration systems, vessels or compressors caused by a process upset or equipment failure. The cartridge safety relief valve (CSR) and high capacity cartridge safety relief valve (CSRH) are intended to prevent the pressure of the vessel from rising more than 10% above the designed working pressure (DWP) of the vessel or the pressure setting of the relief device, whichever is the lower pressure.

The CSR and CSRH safety relief valves were designed and constructed to meet the requirements of Section VIII ASME Boiler and Pressure Vessel Code and ANSI/ASHRAE 15 Code, and they bear the ASME code designator (UV).

The cartridge design makes maintenance and replacement procedures established by IIAR (Bulletin 110, Section 6.6.3) quick and easy, significantly reducing costs. The removal of the cartridge allows the housing to stay in place without the need to disassemble the piping arrangement.

Employing proven principles of design, these safety relief valves are highly reliable and dependable. Precision machined moving

parts manufactured from stainless steel and a PTFE disc to prevent sticking due to corrosion or cold welding, assure valve opening at the set pressure long after installation.

Codes require valve settings equal to or less than DWP of the vessel protected. The type CSR and CSRH safety relief valves are available in six standard settings, from 150 psig to 400 psig in 50 lb. increments. Special settings between 150 psig to 400 psig are also available. To retain the validity of the code symbols, pressure settings and capacity, these valves must be set and sealed at the factory. No major repairs or reconditioning will be done. Contact factory for details.

Note: These cartridge safety relief valves were designed from the existing Parker Hannifin Refrigerating Specialties SR and SRH safety relief valve housing, which allows upgrading to the cartridge design without the need for re-piping.

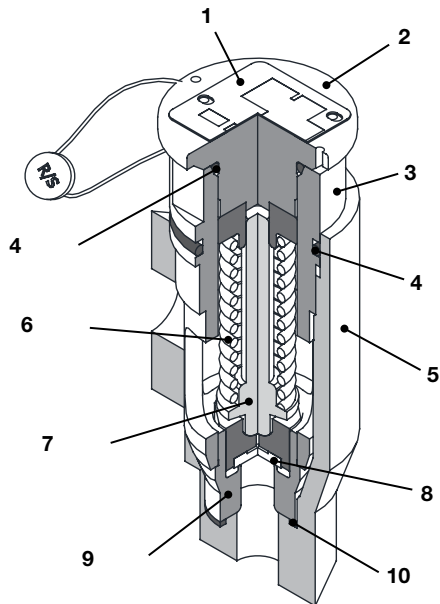

Figure 1: CSR & CSRH Cross-Section

Component	Description	Material
1	Name Plate	Aluminum
2	Cap	Stainless Steel
3	Body	Stainless Steel
4	O-Ring	Neoprene
5	Body	Ductile Iron
6	Pressure Spring	Stainless Steel
7	Stem	Stainless Steel
8	Plug	PTFE
9	Seat	Stainless Steel
10	Gasket	Blue Gylon 3504

Table 3: CSR & CSRH Part Description and Material

Selection Data

The Type SR safety relief valve is intended to prevent the pressure of the vessel from rising more than 10% above the Design Working Pressure (DWP) or the pressure setting of the relief device, whichever is the lower pressure.

Whenever conditions permit, it is advisable to have the relief valve pressure setting (which must not exceed the DWP of the vessel) at least 25% higher than the normal operating pressure for the refrigerant being used.

Pressure limiting devices such as high pressure cutouts on positive displacement compressor systems must stop the action of the pressure imposing element at no higher than 90% of the pressure setting for the pressure relief device.

For non-positive displacement compressors, the pressure limiting device such as a high pressure cut-out may be set at the DWP of the high side provided that the low side is protected by a properly sized pressure relief device, and there are no stop valves in the system that isolate the high side from the low side.

Discharge piping from relief devices must not exceed specified lengths as indicated in ANSI/ASHRAE 15 with discharge to atmosphere.

Per ANSI/ASHRAE 15, the minimum required discharge capacity of a relief device for each pressure vessel where the vessel is valved

off from refrigerating systems is determined as follows: [1.0]

$$C = f D L$$

Where

C = Capacity, kg/s (lb air/min)

D = outside diameter of vessel, m (ft)

L = Length of vessel, m (ft)

f = Factor dependent upon type of refrigerant

Refrigerant	f
Ammonia (R-717)	0.5
R-12, R-22, R-134a, R-407C, R-500	1.6
R-407a	2.0
R-404a, R-410a, R-502, R-507a	2.5
All Others	1.0

Table 5: Refrigerant factor (f) - ANSI/ASHRAE 15

For example, if the vessel contains ammonia and is 6 ft in diameter and 14 ft long, the required safety relief capacity is 42 lb air/min.

Installation

In many localities, state or municipal codes govern selection and installation of relief valves. Many are patterned after the ASME Boiler and Pressure Vessel Code and ANSI/ASHRAE 15 safety code for mechanical refrigeration. Where no compulsory code exist, the ANSI/ASHRAE 15 code is highly recommended.

Vessels with an internal volume greater than 0.28 m³ (10 ft³) must be protected with two relief valves installed on the three-way manifold (M1).

Both the CSR and CSRH valves are for use with ammonia and halocarbon refrigerants in non-corrosive environments. Pressure settings and capacities apply only when the valve is discharging to atmospheric pressure.

All safety relief valves are packaged for maximum protection. Be sure to unpack carefully and check the carton to make sure all items have been unpacked. Save the enclosed instructions for the installer and eventual user.

Do not remove the protective coverings from the inlet and outlet of the safety relief valve until the valve is ready to be installed. Protect the inside of the safety relief from dirt and chips before and during installation.

The safety relief valve should be installed in a location where it is easily accessible for maintenance. The location should be such that the safety relief valve can not be easily damaged by material handling equipment.

The safety relief valve must be installed with the flow arrow on the body pointing in the direction of flow and in the upright position, as illustrated in Figure 2, for the relief valve to work properly. It is not necessary to remove the cartridge from the body, but when installing the safety relief valve to the appropriate manifold or line use the wrench flats on the body. The same installation instructions apply to a single safety relief valve application.

After completing the manifold and dual safety relief valve installation it is important to backseat the manifold so that port 1 is closed off. This is accomplished by turning the stem counterclockwise until it stops, as shown in Figure 3.

Even though the three-way manifold can be seated in either direction, it is recommend to backseat Port 1 because it takes pressure off the packing, thus reducing potential leaks at the stem. Port 1 should be used for maintenance purposes only.

It is important that the nameplates on the safety relief valves remain legible and in good condition to ensure that the replacements are installed in the correct body.

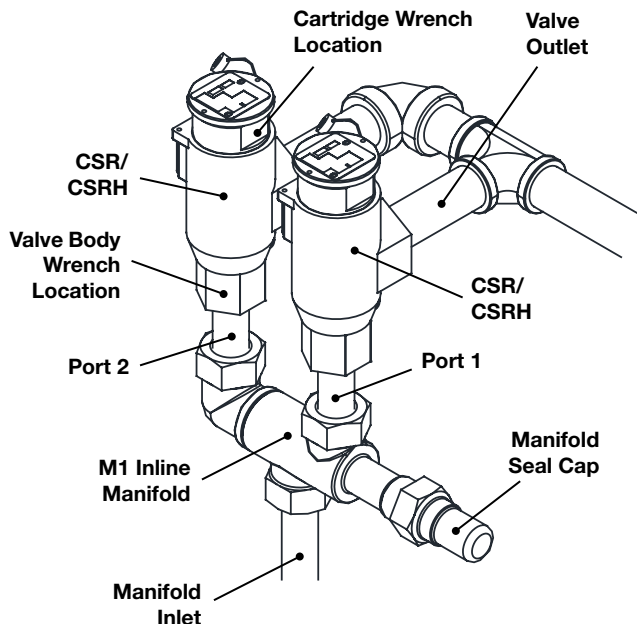

Figure 2: Three-Way Manifold (M1) with Dual Safety Relief Valve Setup Installation Diagram

⚠ Warning

Safety relief valves or replacement cartridges are set and certified to the requirements of Section VIII ASME Boiler and Pressure Vessel Code and ANSI/ASHRAE 15 Code at the factory. If newly purchased safety relief valves are tested by the end user or VR shop prior to installation they no longer comply with the codes and the warranty is voided.

Dimensional Information

Safety Relief Valve		A	B	C	D
CSR1	mm	70	147	40	127
	inch	2.75	5.79	1.56	5.00
CSR2	mm	70	147	40	127
	inch	2.75	5.79	1.56	5.00
CSR3	mm	76	150	48	152
	inch	3.00	5.29	1.88	6.00
CSR4	mm	76	150	48	152
	inch	3.00	5.29	1.88	6.00
CSRH1	mm	70	147	40	127
	inch	2.75	5.79	1.56	5.00
CSRH2	mm	70	147	40	127
	inch	2.75	5.79	1.56	5.00
CSRH3	mm	70	147	40	127
	inch	2.75	5.79	1.56	5.00
CSRH4	mm	104	188	57	178
	inch	4.11	7.4	2.25	7.00
CSRH3	mm	104	188	57	178
	inch	4.11	7.4	2.25	7.00

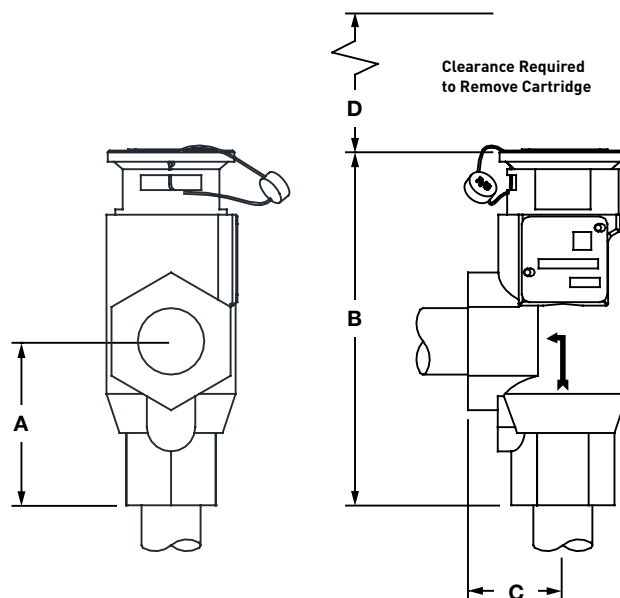

Dual Manifold		Inlet	F	G	H
M1 (1/2")	mm	15	92	84	159
	inch	1/2	3.6	3.3	6.3
M1 (3/4")	mm	20	92	84	159
	inch	3/4	3.6	3.3	6.3
M1 (1")	mm	25	149	101	236
	inch	1	5.9	4.4	9.3
M1 (1 1/4")	mm	32	149	101	236
	inch	1 1/4	5.9	4.4	9.3

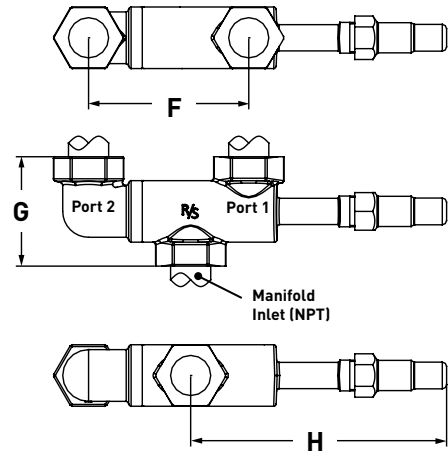

Nameplate Information

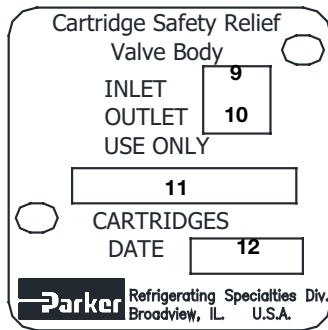
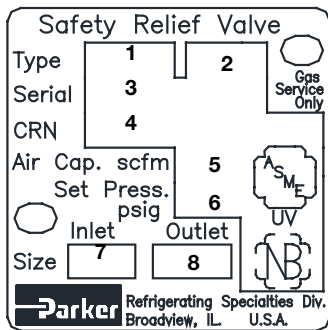

Item	Description
1	Cartridge Model
2	Year of Manufacture, Cartridge
3	Serial Reference Number
4	Canadian Registration Number (CRN)
5	Standard Cubic Feet per Minute of Air (SCFM)
6	Pressure Setting
7	Inlet Body Connection (NPT)
8	Outlet Body Connection (NPT)
9	Inlet Body Connection (NPT)
10	Outlet Body Connection (NPT)
11	Body Model
12	Year of Manufacture, Body

Maintenance and Service

Before disassembling any CSR or CSRH safety relief valves, read the information in this bulletin and the safety procedures for Refrigerating Specialties Division refrigeration control valves bulletin (RSBCV).

To learn more about the components refer to the cross-section, Figure 1, and component description, Table 3, illustrated in this bulletin.

Steps for replacing a safety relief valve cartridge:

1. Before replacing an expired or popped cartridge style safety relief valve, it is important to ensure the safety relief valve is isolated from the rest of the system or vessel by use of a three-way manifold or by following proper pump down procedures. It is also important that any vessel where safety relief valves are being serviced is still protected by an approved safety relief device.

When using a three-way manifold, the proper port must be isolated or back seated prior to the removal of the cartridge. See table 4 for stem position.

Always check the valve set pressure and capacity with the requirements of the system design.

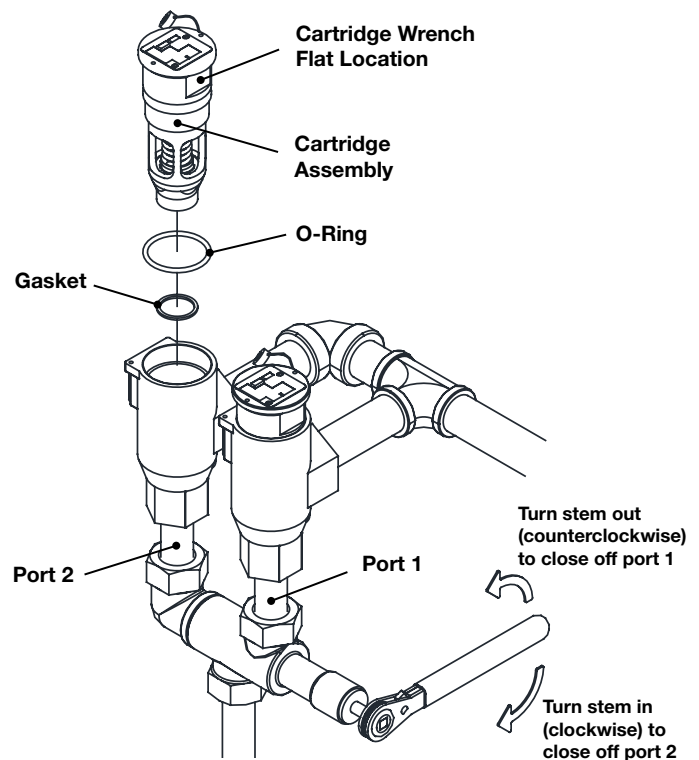

Figure 3: Replacing a Safety Relief Valve Cartridge

Stem Position	Port 1	Port 2
In	Open	Closed
Out	Closed	Open
Mid	Open	Open

Table 4: M1 Manifold Stem Position

- Remove the cartridge from the body by using the wrench flat on the cartridge as show in Figure 3. It may be necessary to hold the valve body while removing the cartridge to prevent the body from unthreading from the pipe.

Do not unscrew the cartridge completely. Crack it enough to allow the trapped ammonia vapor, if any, to escape through the threads. After a few minutes the cartridge can be safely removed.

- Remove the gasket from the bottom of the safety relief body and clean any remaining debris from the gasket and O-ring bore surface.
- Apply a light coating of O-ring grease to the cartridge O-ring before sliding it onto the cartridge. If necessary, reapply after the O-ring has been properly positioned on the cartridge. This will help prevent tearing during the installation and ensure a good seal.
- Place the new gasket at the base of the safety relief valve body.
- Apply a light coat of nickel based anti-seize compound to the cartridge threads before installation. The recommended torque value for adequate sealing of the body to cartridge joint is 61-67 Nm (40-50 ft-lb).

Parts Kit Reference

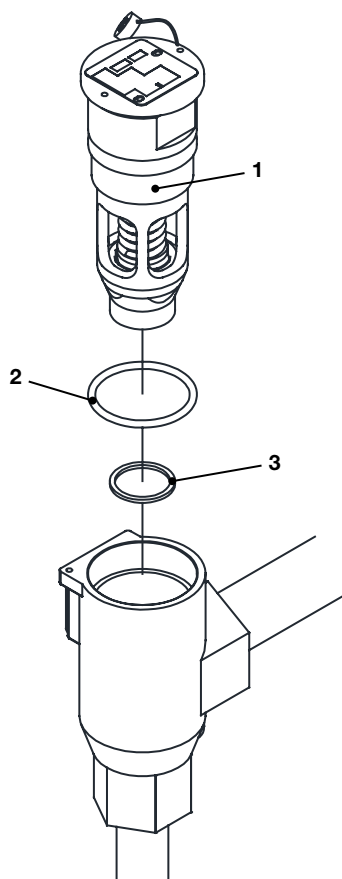

CSR & CSRH Parts Kit Reference											
Item	Description	Kit Description	Kit								
			CSR1	CSR2	CSR3	CSR4	CSRH1	CSRH2	CSRH3	CSRH4	CSRH5
1	Cartridge Assembly	Cartridge Assembly									
		150 psig	209801	209807	210193	210199	209783	209789	209795	210205	210210
2	O-Ring	200 psig	209802	209808	210194	210200	209784	209790	209796	210206	210211
		250 psig	209803	209809	210195	210201	209785	209791	209797	210207	210212
3	Gasket, Cartridge	300 psig	209804	209810	210196	210202	209786	209792	209798	210208	210213
		350 psig	209805	209811	210197	210203	209787	209793	209799	210209	210214
		400 psig	209806	209812	210198	210204	209788	209794	209800	—	—

For non-standard setting please consult factory for cartridge kit.

Safe Operation (See Bulletin RSBCV)

People doing any work on a refrigeration system must be qualified and completely familiar with the system and the Refrigerating Specialties Division valves involved, or all other precautions will be meaningless. This includes reading and understanding pertinent Refrigerating Specialties Division Product Bulletins and Safety Bulletin RSB prior to installation or servicing work.

Where cold refrigerant liquid lines are used, it is necessary that certain precautions be taken to avoid damage which could result from liquid expansion. Temperature increase in a piping section full of solid liquid will cause high pressure due to the expanding liquid which can possibly rupture a gasket, pipe or valve. All hand valves isolating such sections should be marked, warning against accidental closing, and must not be closed until the liquid is removed. Check valves must never be installed upstream of solenoid valves, or regulators with electric shut-off, nor should hand valves upstream of solenoid valves or downstream of check valves be closed until the liquid has been removed.

It is advisable to properly install relief devices in any section where liquid expansion could take place. Avoid all piping or control arrangements which might produce thermal or pressure shock.

For the protection of people and products, all refrigerant must be removed from the section to be worked on before a valve, strainer, or other device is opened or removed. Flanges with ODS connections are not suitable for ammonia service.

Warranty

All Refrigerating Specialties products are under warranty against defects in workmanship and materials for a period of one year from date of shipment from factory. This warranty is in force only when products are properly installed, field assembled, maintained, and operated in use and service as specifically stated in Refrigerating Specialties Catalogs or Bulletins for normal refrigeration applications, unless otherwise approved in writing by the Refrigerating Specialties Division. Defective products, or parts thereof returned to the factory with transportation charges prepaid and found to be

defective by factory inspection, will be replaced or repaired at Refrigerating Specialties option, free of charge, F.O.B. factory. Warranty does not cover products which have been altered, or repaired in the field, damaged in transit, or have suffered accidents, misuse, or abuse. Products disabled by dirt or other foreign substances will not be considered defective.

The express warranty set forth above constitutes the only warranty applicable to Refrigerating Specialties products, and is in lieu of all other warranties, expressed or implied, written including any warranty of merchantability, or fitness for a particular purpose. In no event is Refrigerating Specialties responsible for any consequential damages of any nature whatsoever. No employee, agent, dealer or other person is authorized to give any warranties on behalf of Refrigerating Specialties, nor to assume, for Refrigerating Specialties, any other liability in connection with any of its products.

**ISO 9001 CERTIFIED**